

Industrial Drum Pump Packages

PUMP PACKAGE 2

Acids & Alkalis

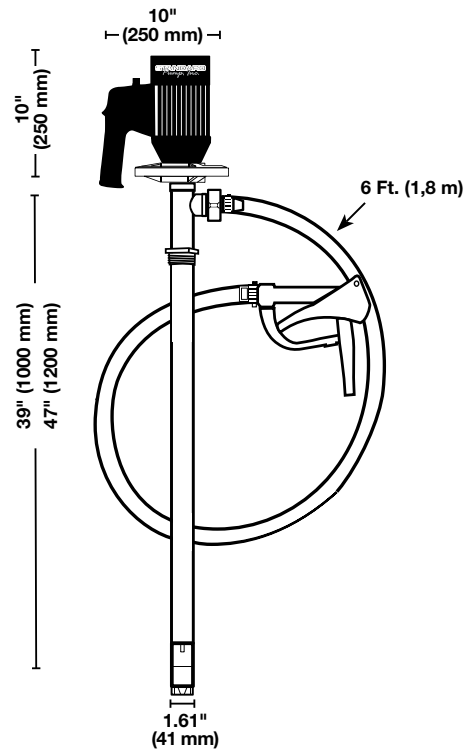

Technical Specifications

Package:Motor, Pump, Hose, Storage Bracket
Barrel Adapter & Hand Nozzle

Motor Type:Open Drip Proof (IP 44)

Pump Assembly:Polypropylene

Pump Length:..... 39" (1000 mm) or 47" (1200 mm)

Discharge Hose:..... PVC, 6 ft (1,8 m), 1" (25 mm) I.D.

Hand Nozzle: Polypropylene, 1" (25 mm)

Maximum Flow Rate:..... 15 GPM (57 LPM) *based on water*

Maximum Viscosity: 1500 cps (mPas)

Maximum Temperature: 130° F (55° C)

Shipping Weight:..... 22 lbs. (9,97 kg)

Package Numbers:

Drums:

Pkg P/N	Motor	Volts	Pump Tube
9400	SP-280P-V	110V	SP-PP-39
9401	SP-280P-2-V	220V	SP-PP-39

Tanks:

Pkg P/N	Motor	Volts	Pump Tube
9402	SP-280P-V	110V	SP-PP-47
9403	SP-280P-2-V	220V	SP-PP-47

STANDARD
Pumps, Inc.

www.standardpump.com

Toll Free: 1-866-558-8611

Tel 770-307-1003